

FEATURES

- Eight optically isolated, non-polarized digital inputs
- Switchable filters on inputs for electrically noisy environments
- Eight electro-mechanical relay outputs
- Optically isolated channel to channel and channel to ground
- Can detect input state change and assert interrupt
- Automatically detected under Windows

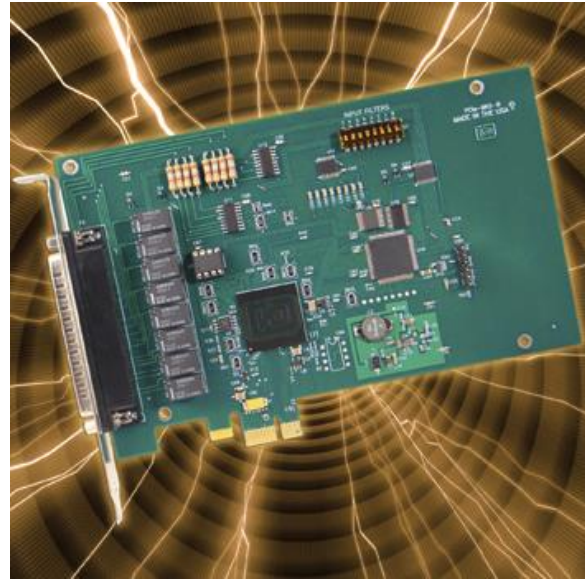

FUNCTIONAL DESCRIPTION







This product is a x1 lane PCIe isolated digital input and relay output board with Change of State (COS) detection capabilities.

The isolated inputs can be driven by either AC or DC and are not polarity sensitive. Input signals are rectified by a diode bridge and applied to the inputs of opto-isolators. A 1.8k ohm resistor in series provides current limiting. Standard 12/24 AC control transmitter outputs can be accepted as well as DC voltages. The input voltage range is 3V to 31V (rms). To extend the input voltage range, you may connect external resistors in series.

The electro-mechanical relay outputs of the PCIe-IIRO-8 are comprised of five form C SPDT outputs and three Form A SPST (normally-open) type. The relays are all de-energized at power-on. Data to the relays is latched.

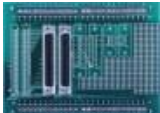
The card is 6.6 inches in length and 4.2 inches seated height. I/O wiring connections for this board are via a male 37-pin D-sub connector. A ribbon cable can be used to connect this card to termination panels.

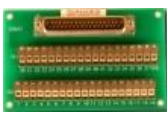
ACCESSORIES

ADAP37	CAB37-XX	STA-37	T-BOX	STB-37	DIN-SNAP-6
DB37F screw terminal board plugs directly onto the card's I/O connector	Ribbon Cable Assy, XX=length in inches	Screw terminal board mounted on standoffs with bread-board area	Metal enclosure with powder coated finish, use to mount STA-37 to panel	Screw terminal board, ships with standoffs but can also mount on SNAP-TRACK or DIN-SNAP	SNAP-TRACK for DIN-rail mounting one STB-37
					

SOFTWARE

The card is supported for use in most operating systems and includes a free DOS, Linux, and Windows 2000/XP/2003/Vista/7 compatible software package. This package contains sample programs and source code in Visual Basic, Delphi, and Visual C++ for Windows. Also provided is a graphical setup program in Windows. Linux support includes installation files and basic samples for programming from user level via an open source kernel driver. Third party support includes a Windows standard DLL interface usable from the most popular application programs. Embedded OS support includes Windows XPe.

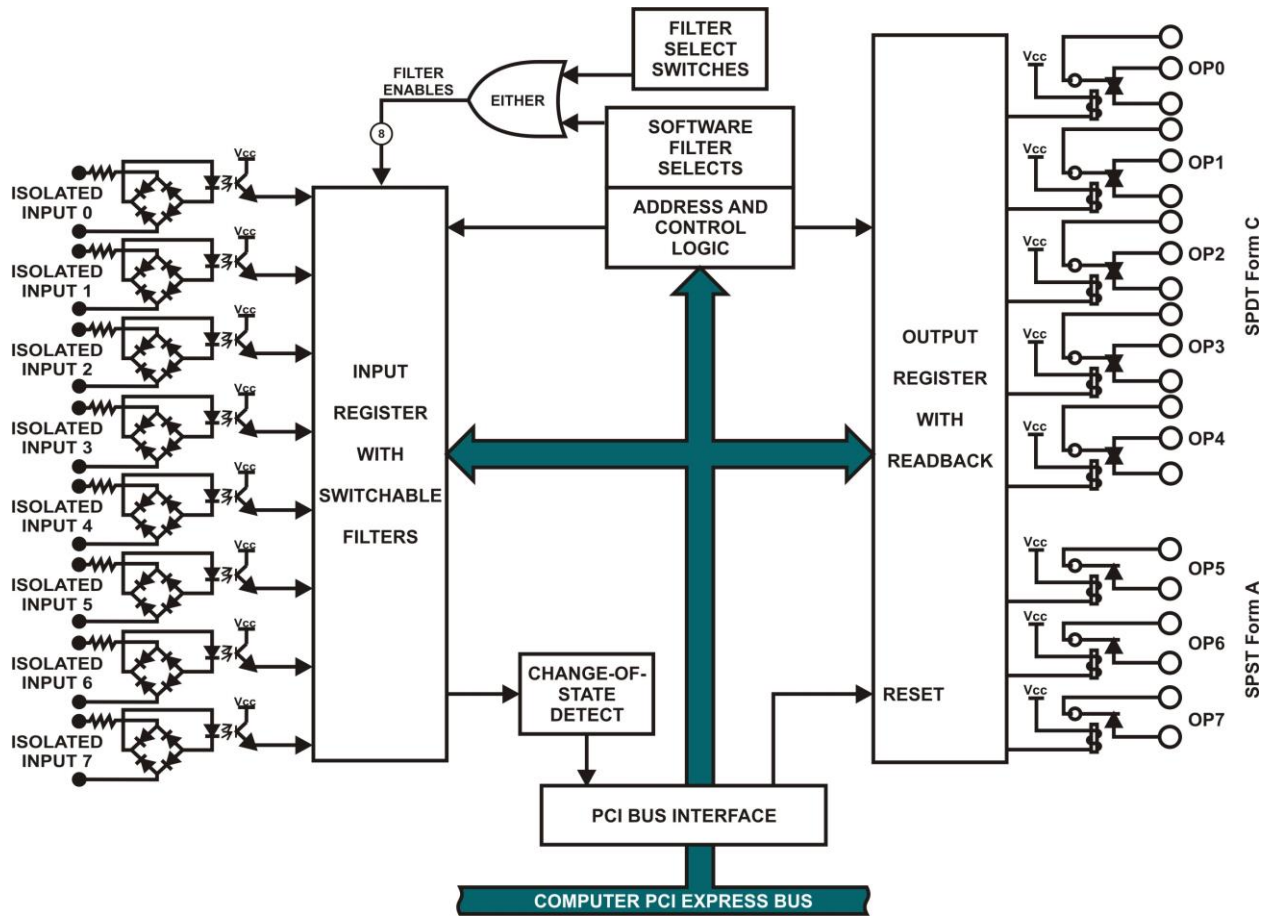

BLOCK DIAGRAM

SPECIFICATIONS

Digital Inputs

Number of inputs: 8
 Type: Non-polarized, optically isolated from each other and from the computer. (not TTL/CMOS compatible)
 Voltage Range: 3 to 31V DC or AC (40 to 10kHz)
 Isolation: 500V*(see manual) channel to channel and channel to ground
 Input Resistance: 1.8k ohms in series with two diodes and a photo-coupler LED
 Response Time: 10 mSec w/filter, 20 uSec w/o filter

Relay Outputs

Number of outputs: 8
 Contact Rating: 2A carry current
 Contacts: Channels 0-4 are SPDT Form C and channels 5-7 are SPST Form A.
 Contact Rating: Initial 100 milliohms maximum
 Contact Life: mech'l: 5 million operations minimum; elect'l: 5 million ops min at full load
 Operating Time: 2 milliseconds maximum
 Release Time: 1 milliseconds maximum
 Regulatory: UL and CSA
 Interrupts: Enabled by software, generated when digital inputs change state.

Power Required

+5VDC 0.510A (all relays ON)

Environmental

Operating: 0 to +70°C
 Storage: -40 to +85°C
 Humidity: 5 to 95 percent (non-condensing)
 Weight: Approx. 8 oz. (227 grams)
 Size: 6.15" (156 mm) long

ORDERING GUIDE

PCIe-IIRO-8 8 isolated inputs and 8 relay outputs

DB37M Connector Pin Assignments

Signal Name	Pin	Signal Name	Pin
		IP7	1
IP7	20	IP6	2
IP6	21	IP5	3
IP5	22	IP4	4
IP4	23	IP3	5
IP3	24	IP2	6
IP2	25	IP1	7
IP1	26	IP0	8
IP0	27	OP7 C	9
OP7 NO	28	OP6 C	10
OP6 NO	29	OP5 C	11
OP5 NO	30	OP4 NC	12
OP4 C	31	OP4 NO	13
OP3 NC	32	OP3 C	14
OP3 NO	33	OP2 NC	15
OP2 C	34	OP2 NO	16
OP1 NC	35	OP1 C	17
OP1 NO	36	OP0 NC	18
OP0 C	37	OP0 NO	19

